

REVISIONS			
REV.	DESCRIPTION	BY	DATE
A	INITIAL RELEASE	JJ	10/1/2010

QUICK REFERENCE			
CONTROLLER	CASE SIZE	MOUNTING	VERSION
400	6	DESKTOP	LITE

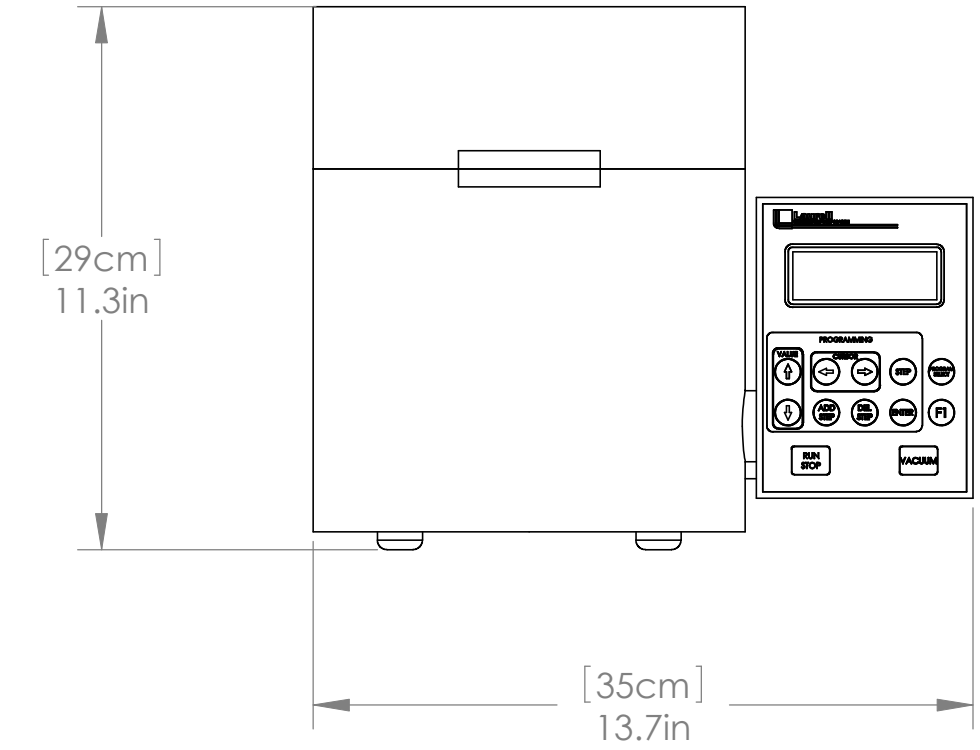
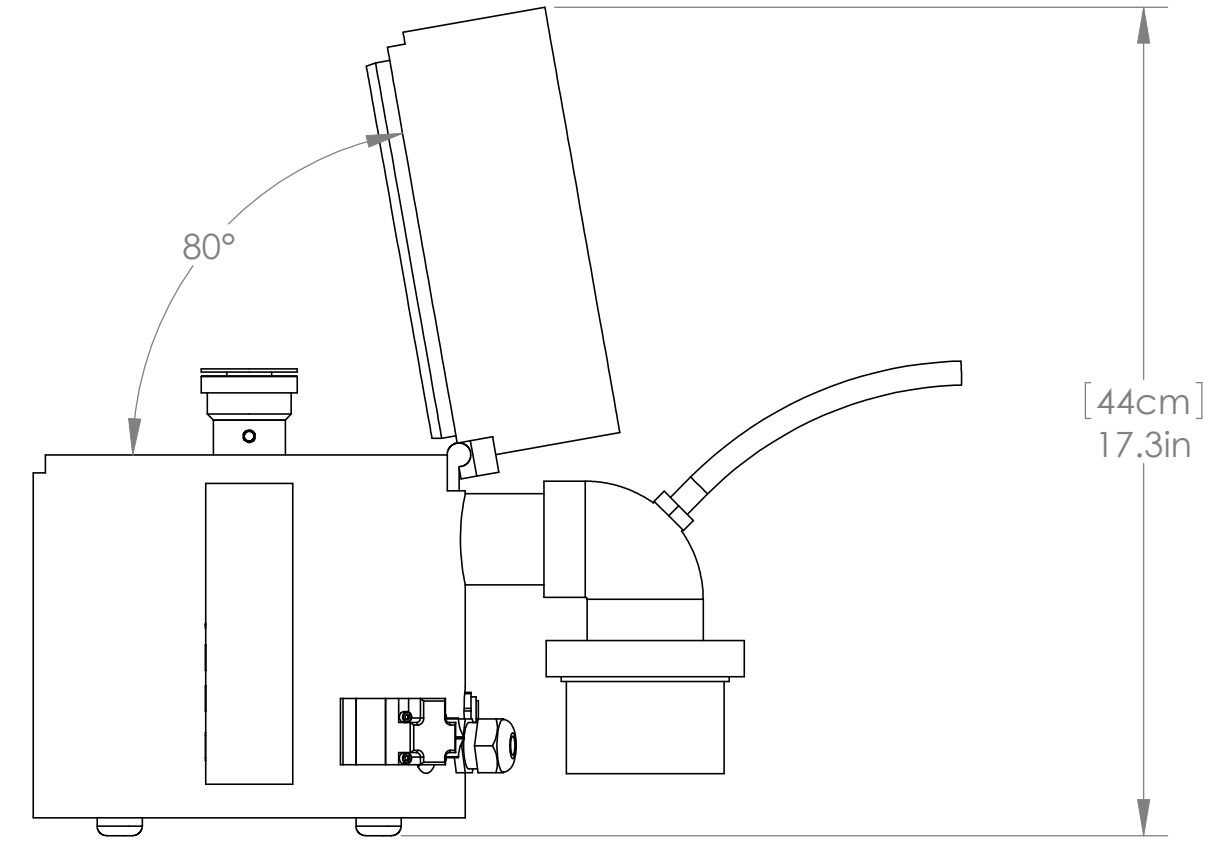
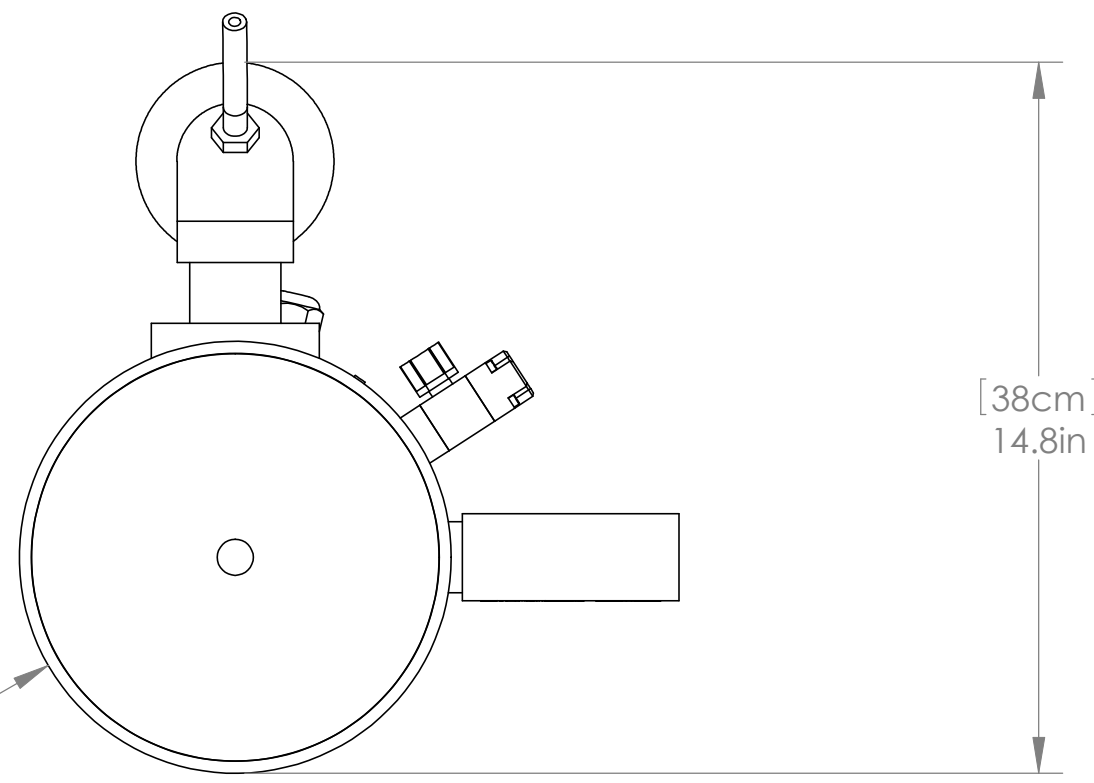

PROPRIETARY AND CONFIDENTIAL
 THE INFORMATION CONTAINED IN THIS DRAWING IS THE SOLE PROPERTY OF LAURELL TECHNOLOGIES. ANY REPRODUCTION IN PART OR AS A WHOLE WITHOUT THE WRITTEN PERMISSION OF LAURELL TECHNOLOGIES IS PROHIBITED.

UNLESS OTHERWISE SPECIFIED:		NAME	DATE		
DIMENSIONS ARE IN INCHES		DRAWN	JJ		TITLE: DIMENSIONAL DRAWING, WS-400-6NPP LITE
TOLERANCES:		CHECKED			
FRACTIONAL ±.015		ENG APPR.			
ANGULAR: MACH ± 1/2°		MFG APPR.			
TWO PLACE DECIMAL ±.01		Q.A.			
THREE PLACE DECIMAL ±.005		COMMENTS:		SIZE DWG. NO. REV B 10077601 A	
INTERPRET GEOMETRIC TOLERANCING PER:		ALL PARTS MUST BE CLEAN AND FREE OF BURRS. BREAK ALL SHARP EDGES, .015" RADIUS MAX.			
MATERIAL		SCALE: 1:8 WEIGHT: SHEET 1 OF 1			
FINISH	DO NOT SCALE DRAWING				
NEXT ASSY	USED ON				
APPLICATION					